





产品图片	Features 产品特性	Application 应用
 DIP6  SMD6	<ul style="list-style-type: none"> ●Contact Form 触点形式 1a ●Load Voltage 输出电压 600V ●Load Current 输出电流 0.08A ●Low Off-State Leakage Current 漏电流 1μA 	<ul style="list-style-type: none"> ●Automatic Test Equipment 自动检测设备 ●Telephone Equipment 通信设备 ●Sensing Equipment 传感设备 ●Security Equipment 安全设备 ●I/O Modules I/O 模块 ●Modem 调制解调器

Type 种类

Output rating 输出额定		Marking model 标 刻型号	Part No. 订货型号	
Load voltage 负载电压	Load current 负载电流		DIP 双列直插	SMD 表面贴装
600V	0.08A	BCV216	BCV216	BCV216A

注：表示引脚类型的“A”未标刻在产品上，订货依据订货示例型号。

Dimensions 外形尺寸

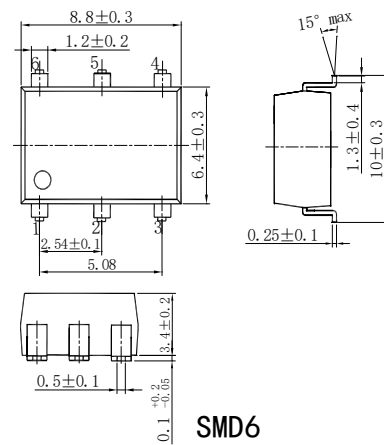
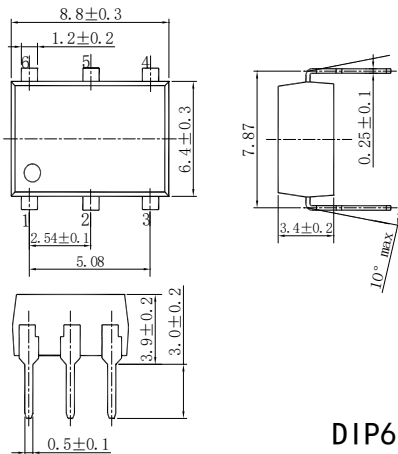

Terminal Identification 引脚标识

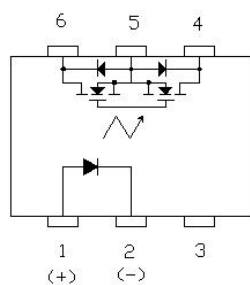

Wiring Diagram 接线图

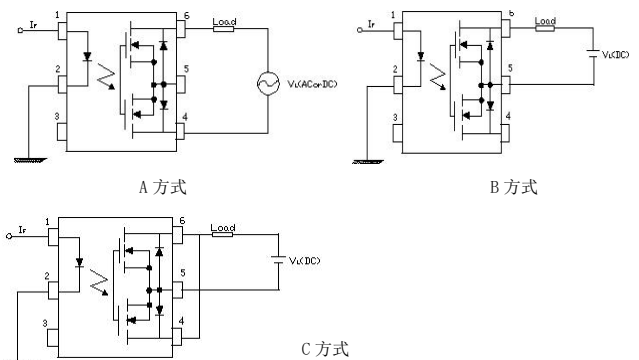

通讯地址：陕西省西安市国家民用航天产业基地航天中路385号众创广场11层1101.1102.1104室

生产地址：陕西省宝鸡市陈仓区群力路1号 邮政编码：721300

电话：(0917)-6293969 18609177833

传 真：(0917)-6293969



PhotoMOS 光 MOS 继电器 (SMD6/DIP6)

Technical parameters 技术参数 (Ambient Temperature 25°C)

I/O Absolute Maximum Ratings 输入输出电气参数最大值

Item 项目	Symbol 符号	BCV216		
Operating Temperature 工作温度	T_{OPR}	-40°C ~ +85°C		
Storage Temperature 储存温度	T_{STG}	-40°C ~ +100°C		
Input 输入	Continuous LED Current 工作电流	MAX. 最大值	I_F	50mA
	Peak LED Current LED 峰值电流 (f=100Hz, Duty=1%)	MAX. 最大值	I_{FP}	1000mA
	LED Reverse Voltage 反向电压	MAX. 最大值	V_R	5V
	Input Power Dissipation 输入功耗	MAX. 最大值	P_{IN}	75mW
Output 输出	Load Voltage 输出电压	MAX. 最大值	V_L	600V (AC peak or DC)
	Load Current 输出电流	MAX. 最大值	I_L	0.08A
	Peak Load Current 峰值输出电流 (100ms, 1shot)	MAX. 最大值	I_{PEAK}	0.12A
	Output Power Dissipation 输出功耗	MAX. 最大值	P_{OUT}	450mW
Total Power Dissipation 总功耗	MAX. 最大值	P_T	500mW	
I/O Breakdown Voltage 输入输出间隔离电压	MAX. 最大值	$V_{I/O}$	3750Vrms	
I/O Breakdown Voltage 输入输出间隔离电压 (加注 H)	MAX. 最大值	$V_{I/O}$	5000Vrms	

Electrical Specifications 输入输出电气参数

Item 项目	Symbol 符号	BCV216	Conditions 条件		
Input 输入	LED Forward Voltage 正向电压	TYP. 典型值	V_F	1.2V	$I_F=10mA$
		MAX. 最大值		1.5V	
	Operation LED Current 接通电流	TYP. 典型值	$I_{F ON}$	0.5mA	
		MAX. 最大值		5mA	
Recovery LED Voltage 关断电压	MIN. 最小值	$V_{F OFF}$	0.7V		
Output 输出	On-Resistance 导通电阻	TYP. 典型值	R_{ON}	35 Ω	$I_F=5mA, I_L=Rating,$ within 1 sec.
		MAX. 最大值		70 Ω	
	Off-State Leakage Current 漏电流	MAX. 最大值	I_{LEAK}	1 μA	$V_L=Rating$
Output Capacitance 输出端容量	TYP. 典型值	C_{OUT}	100pF	$V_L=0V, f=1MHz$	
Time parameters 时间参数	Turn-On Time 接通时间	TYP. 典型值	T_{ON}	0.5ms	$I_F=5mA, I_L=Rating$
		MAX. 最大值		1ms	
	Turn-Off Time 关断时间	TYP. 典型值	T_{OFF}	0.02ms	
		MAX. 最大值		0.2ms	
I/O 输入输出	I/O Insulation Resistance 绝缘电阻	MIN. 最小值	$R_{I/O}$	1000M Ω	DC500V
	I/O Capacitance 隔离电容	TYP. 典型值	$C_{I/O}$	0.8pF	f=1MHz
		MAX. 最大值		1.5pF	

通讯地址: 陕西省西安市国家民用航天产业基地航天中路385号众创广场11层1101.1102.1104室

生产地址: 陕西省宝鸡市陈仓区群力路1号 邮政编码: 721300

电话: (0917)-6293969 18609177833

传 真: (0917)-6293969



PhotoMOS 光 MOS 继电器 (SMD6/DIP6)

Reference Data 参考数值 (BCV216)

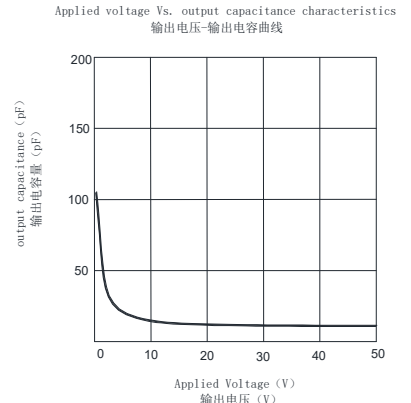
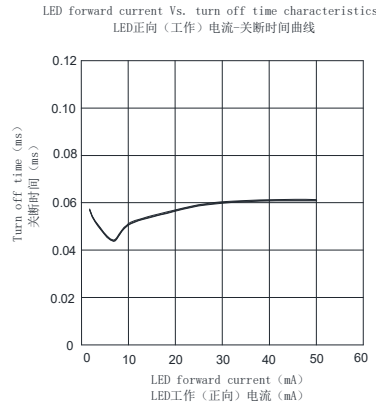
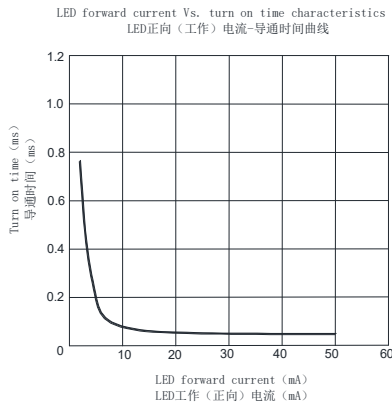
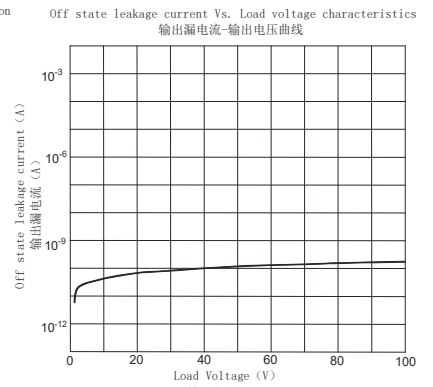
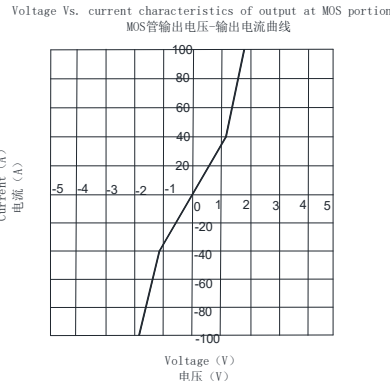
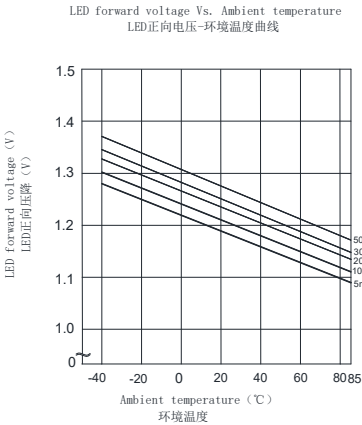
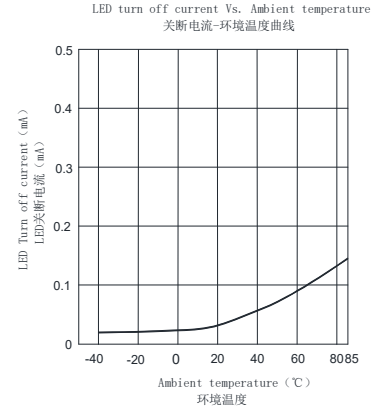
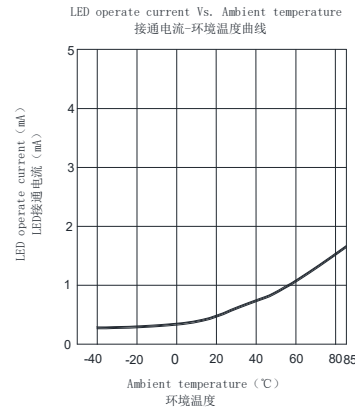
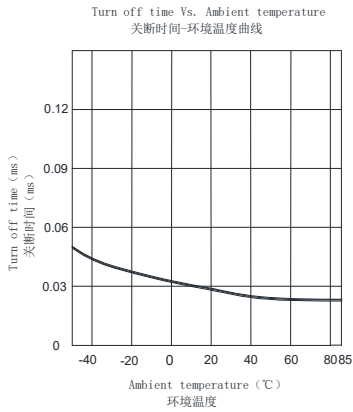
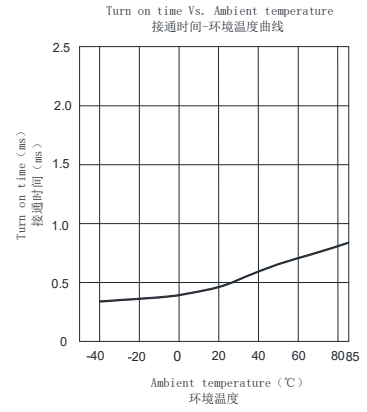
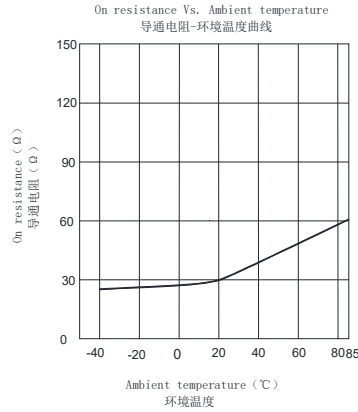
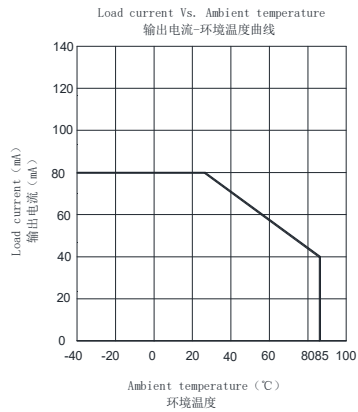

通讯地址: 陕西省西安市国家民用航天产业基地航天中路385号众创广场11层1101.1102.1104室

生产地址: 陕西省宝鸡市陈仓区群力路1号 邮政编码: 721300

电话: (0917)-6293969 18609177833

传 真: (0917)-6293969